

Linea Bellagio



LB-1100

www.lineabellagio.com

C-TECH-I is proud to present its newest collection, "Linea Bellagio", an exclusive new generation of sinks specifically designed for all solid surface materials, including Quartz and Granite. Linea Bellagio sinks have been designed to integrate and install into your countertop as an under-mount. This feature minimizes bacteria entrapment, makes cleaning easier and brings the latest style into your new kitchen. Thank you again and enjoy your new sink from "Linea Bellagio" by C-TECH-I.



FEATURES

Model #	LB-1100
Description	DOUBLE BOWL KITCHEN SINK
Material	18/10 304 STAINLESS STEEL
Color	STAINLESS STEEL
Mounting options	UNDER-MOUNT
Finish	BOWLS AND SURFACE BRUSHED
Thickness	16 GAUGE
Sound proofing	10 POINT SOUND PAD SYSTEM
Construction type	PRESSED AND WELDED
Construction method	HAND MADE
Warranty	LIMITED LIFETIME
Overflow	NO
Drain size	3 5/8", STANDARD USA, CA AND EUROPE SIZE
Certifications	CAN/CSA-B45/ANSI-A112.19/ANSI-Z124/MASS
FGP Compliant	YES
Fits cabinet size	MADE FOR CABINETS 33" AND LARGER

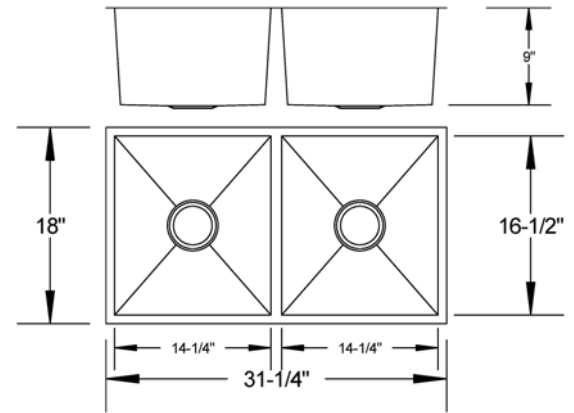

INCLUSIONS:

Your Linea Bellagio sink includes the following accessories,
Paper template for cut-out
Mounting hardware

OPTIONAL ACCESSORIES:

The following accessories are available for your sink,



RESOURCES:

Installation instructions www.specs.ctechi.com/sinkinstall.pdf
Cleaning instructions www.specs.ctechi.com/cleaning.pdf
Warranty information www.specs.ctechi.com/warranty.pdf
DXF file www.specs.ctechi.com/lb-1100.dxf

For your protection and to insure the highest quality and standards, all C-TECH-I products meet or exceed one or more of the regulatory certification marks for the USA, Canada and Europe.



C-TECH-I
Unique elegance and style